

NOTES:

NOT THE SAME AS AN "ACCESSORY STRUCTURE"
(SHED, GARAGE, POOL HOUSE, ART STUDIO, ETC.)

ALLOWED UNDER ZONING BYLAW, SECTION 4.2.2.2

BY RIGHT, UP TO 750 S.F., OR
BY SPECIAL PERMIT, UP TO 1,000 S.F.

FOR REFERENCE:

UNLESS OTHERWISE SHOWN, WATER
METERS SHALL BE INSTALLED WITHIN
THE BUILDING STRUCTURE.

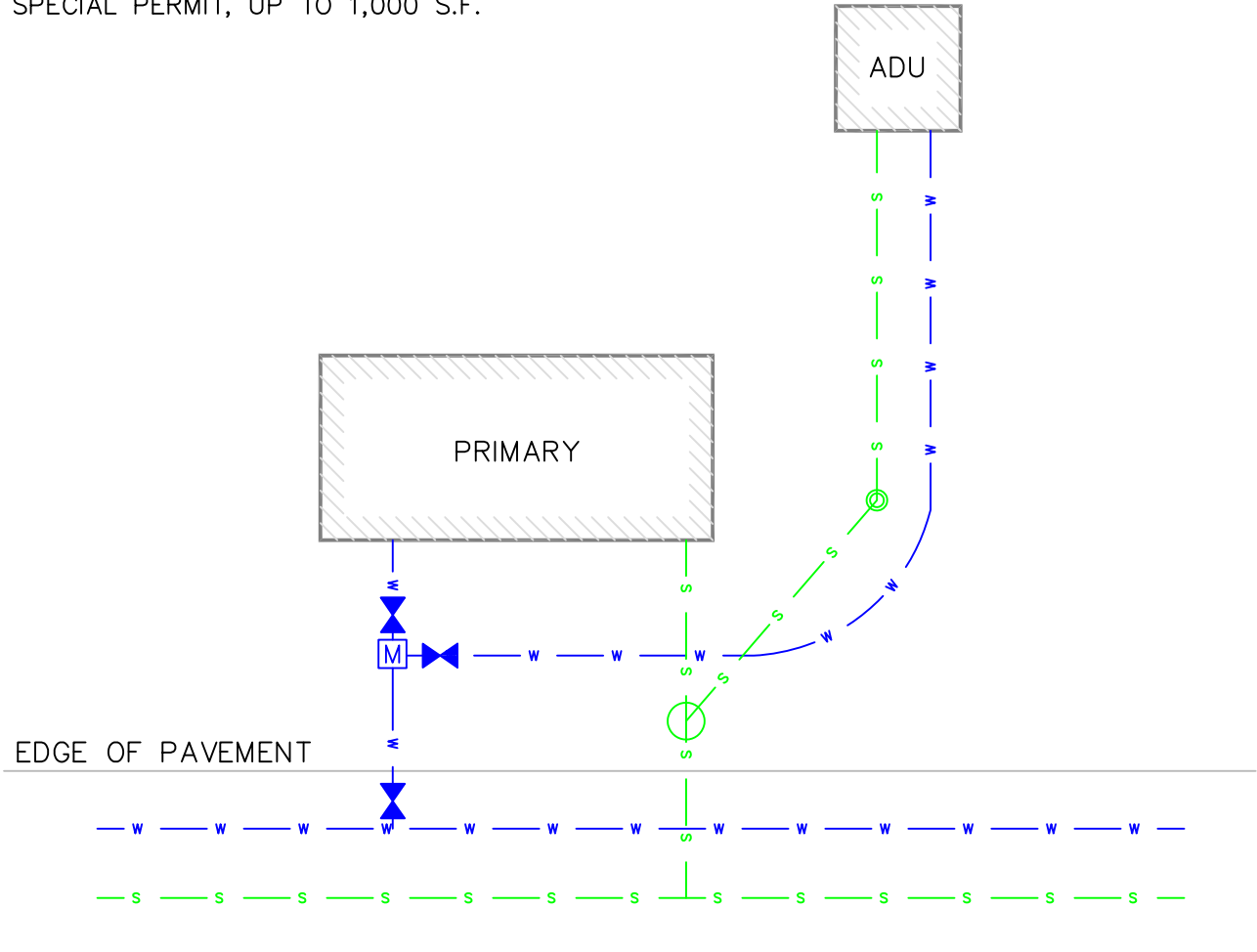

DETACHED ACCESSORY DWELLING UNIT (ADU)

CONFIGURATION STANDARDS APPROVED AS POLICY
BY CONCORD PUBLIC WORKS COMMISSION ON
MARCH 8, 2023.

<u>LEGEND</u>	
SEWER LINE	— s —
WATER LINE	— w —
WATER METER PIT	— [M] —
WATER VALVE	— [V] —
SEWER MANHOLE	— (S) —
SEWER CLEANOUT	— (S) —

TOWN OF CONCORD—PUBLIC WORKS
WATER & SEWER DIVISION
STANDARDS

*ACCESSORY DWELLING UNIT AND
ACCESSORY STRUCTURE TYP. LAYOUTS*

SCALE: NONE DATE: 02/28/2023

JOB NO. \ FILE NAME:	DESIGNED BY: G.G.C.	PLAN NO.
FILE.DWG	DRAWN BY: G.G.C.	1 OF 6
	CHECKED BY: J.A.M.	

NOTES:

WITH NO INTERCONNECTED PLUMBING:

- 2 WATER SERVICES & 2 SERVICE METERS
- 1 SHARED SEWER SERVICE

REQUIRES CERTIFICATION BY PLUMBER:

"NO INTERCONNECTION", OR NO POSSIBILITY OF INTERCONNECTION VIA A SHARED PLUMBING WALL (SEE REGULATIONS).

FOR REFERENCE:

UNLESS OTHERWISE SHOWN, WATER METERS SHALL BE INSTALLED WITHIN THE BUILDING STRUCTURE.

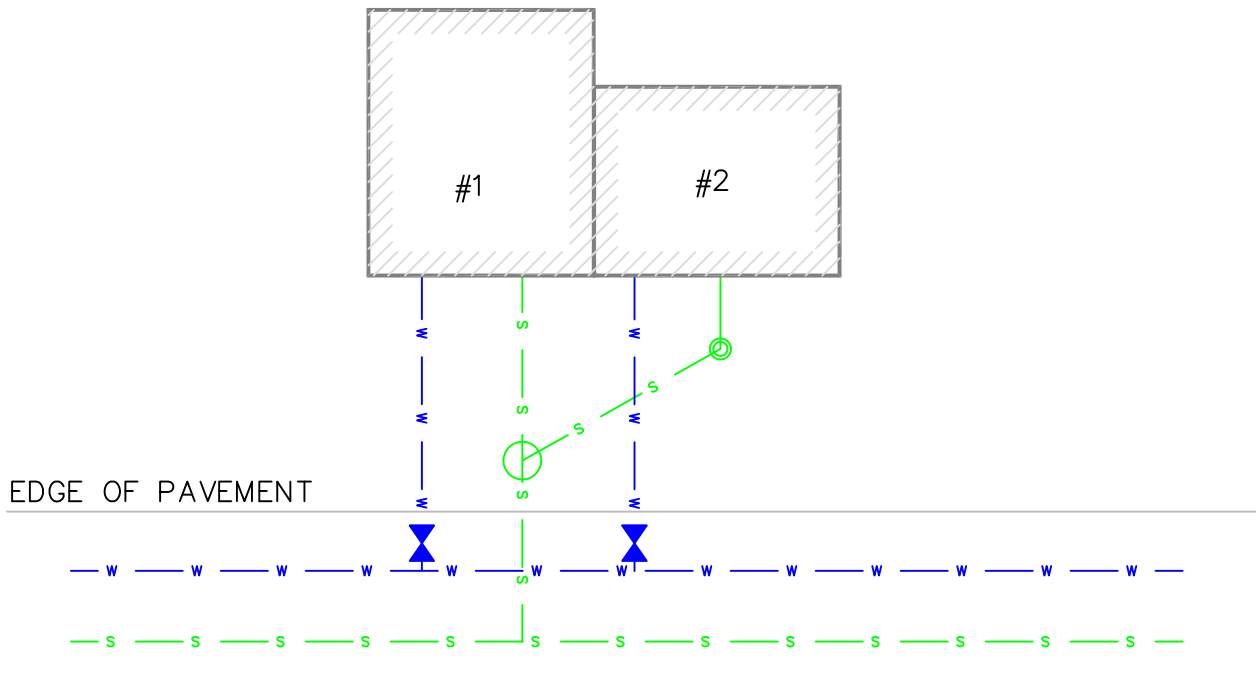

TWO-FAMILY DWELLING (NEW CONSTRUCTION
SIDE-BY-SIDE ATTACHED ADDITION)

CONFIGURATION STANDARDS APPROVED AS POLICY BY CONCORD PUBLIC WORKS COMMISSION ON MARCH 8, 2023.

LEGEND	
SEWER LINE	— s —
WATER LINE	— w —
WATER METER PIT	— [M] —
WATER VALVE	— [V] —
SEWER MANHOLE	— () —
SEWER CLEANOUT	— (X) —

 TOWN OF CONCORD—PUBLIC WORKS WATER & SEWER DIVISION STANDARDS		
<i>ACCESSORY DWELLING UNIT AND ACCESSORY STRUCTURE TYP. LAYOUTS</i>		
SCALE: NONE		DATE: 02/28/2023
JOB NO. \ FILE NAME:	DESIGNED BY: G.G.C.	PLAN NO.
FILE.DWG	DRAWN BY: G.G.C.	2 OF 6
	CHECKED BY: J.A.M.	

NOTES:

- 1 WATER SERVICE & 1 SERVICE METER
- 1 SHARED SEWER SERVICE

FOR REFERENCE:

UNLESS OTHERWISE SHOWN, WATER METERS SHALL BE INSTALLED WITHIN THE BUILDING STRUCTURE.

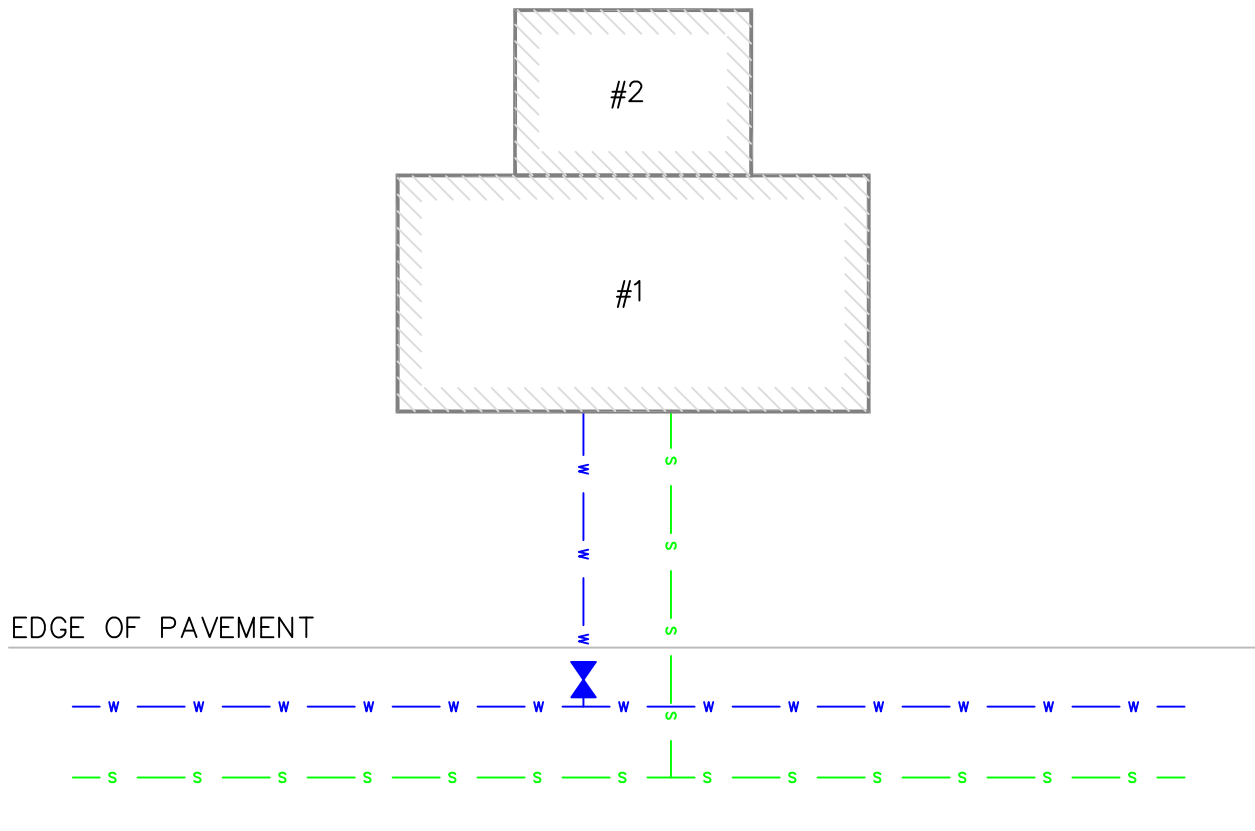

REAR-ATTACHED ADU (CONVERSION OF EXISTING STRUCTURE, OR BY NEW CONSTRUCTION ADDITION)

CONFIGURATION STANDARDS APPROVED AS POLICY BY CONCORD PUBLIC WORKS COMMISSION ON MARCH 8, 2023.

LEGEND	
SEWER LINE	— s —
WATER LINE	— w —
WATER METER PIT	— [M] —
WATER VALVE	— [V] —
SEWER MANHOLE	— () —
SEWER CLEANOUT	— (C) —

 TOWN OF CONCORD—PUBLIC WORKS WATER & SEWER DIVISION STANDARDS		
<i>ACCESSORY DWELLING UNIT AND ACCESSORY STRUCTURE TYP. LAYOUTS</i>		
SCALE: NONE		DATE: 02/28/2023
JOB NO. \ FILE NAME:	DESIGNED BY: G.G.C.	PLAN NO.
FILE.DWG	DRAWN BY: G.G.C.	3 OF 6
	CHECKED BY: J.A.M.	

NOTES:

- 1 WATER SERVICE & 1 SERVICE METER
- 1 SHARED SEWER SERVICE

FOR REFERENCE:

UNLESS OTHERWISE SHOWN, WATER METERS SHALL BE INSTALLED WITHIN THE BUILDING STRUCTURE.

"ATTIC" OR "BASEMENT" ADU

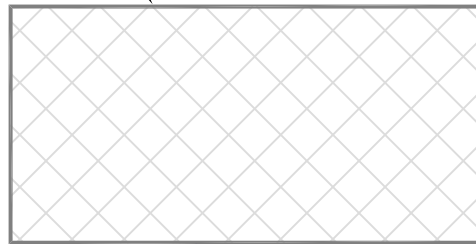

EDGE OF PAVEMENT

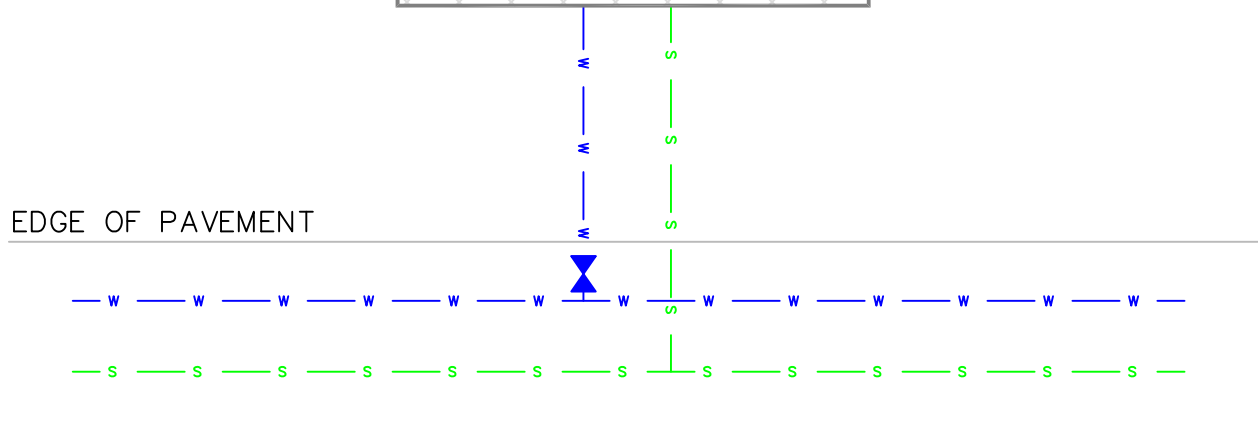

"ATTIC" OR "BASEMENT" ADU
(CONVERSION OF EXISTING STRUCTURE)

CONFIGURATION STANDARDS APPROVED AS POLICY BY CONCORD PUBLIC WORKS COMMISSION ON MARCH 8, 2023.

LEGEND	
SEWER LINE	
WATER LINE	
WATER METER PIT	
WATER VALVE	
SEWER MANHOLE	
SEWER CLEANOUT	

TOWN OF CONCORD—PUBLIC WORKS WATER & SEWER DIVISION STANDARDS		
<i>ACCESSORY DWELLING UNIT AND ACCESSORY STRUCTURE TYP. LAYOUTS</i>		
SCALE: NONE		DATE: 02/28/2023
JOB NO. \ FILE NAME:	DESIGNED BY: G.G.C.	PLAN NO.
FILE.DWG	DRAWN BY: G.G.C.	4 OF 6
	CHECKED BY: J.A.M.	

NOTE:

IF THE ACCESSORY STRUCTURE WERE TO BE CONVERTED TO ADU USE, SERVICES MUST BE CONVERTED TO CONFORM TO PLAN 1 OF 6.

FOR REFERENCE:

UNLESS OTHERWISE SHOWN, WATER METERS SHALL BE INSTALLED WITHIN THE BUILDING STRUCTURE.

- EXAMPLES: GARAGE
WORKSHOP/
ART STUDIO
POOL HOUSE
SHED
BARN

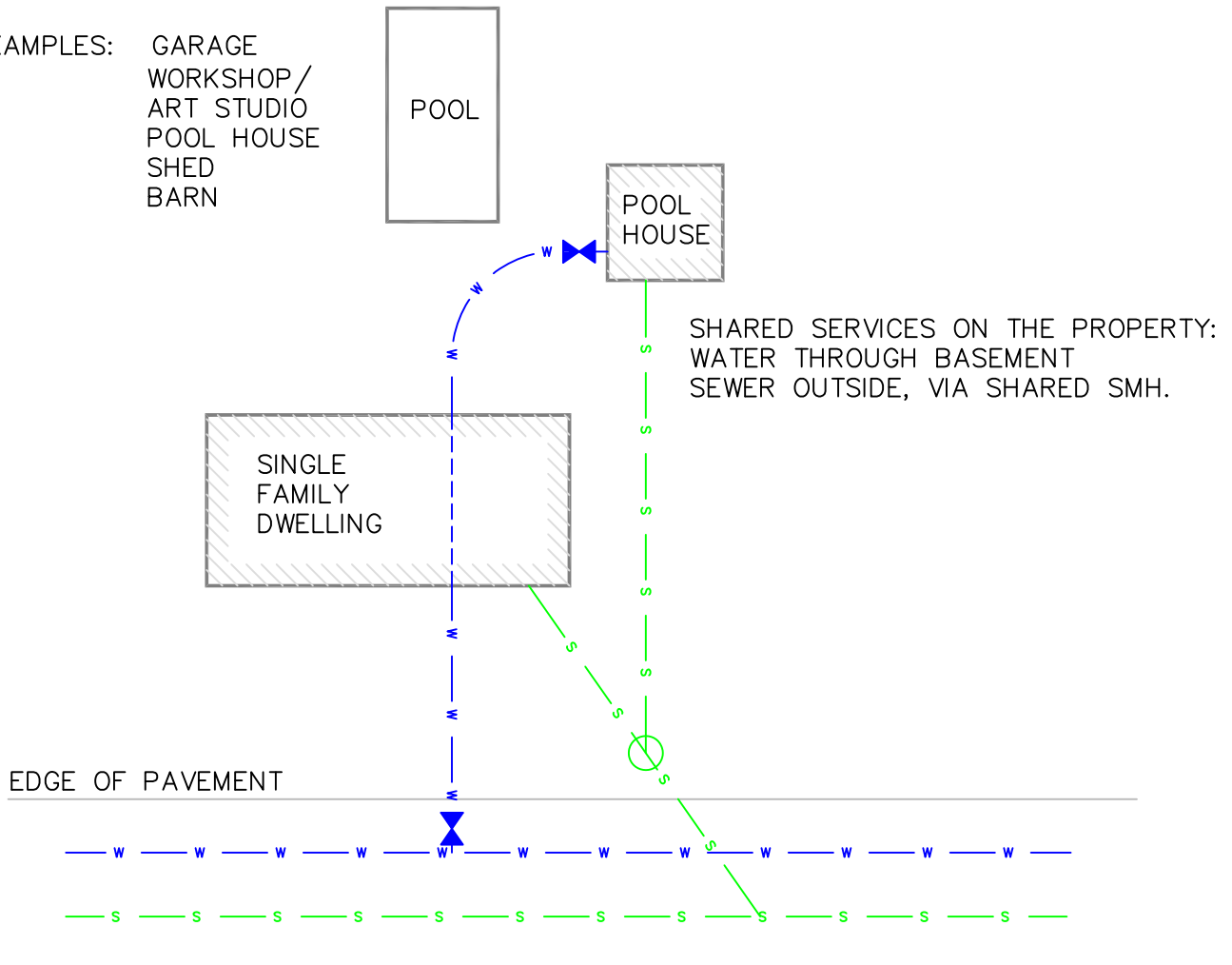

ACCESSORY STRUCTURE
(NOT FOR DWELLING)

CONFIGURATION STANDARDS APPROVED AS POLICY BY CONCORD PUBLIC WORKS COMMISSION ON MARCH 8, 2023.

LEGEND	
SEWER LINE	— s —
WATER LINE	— w —
WATER METER PIT	— [M] —
WATER VALVE	— [Valve Symbol] —
SEWER MANHOLE	— [Manhole Symbol] —
SEWER CLEANOUT	— [Cleanout Symbol] —

TOWN OF CONCORD—PUBLIC WORKS
WATER & SEWER DIVISION
STANDARDS

*ACCESSORY DWELLING UNIT AND
ACCESSORY STRUCTURE TYP. LAYOUTS*

SCALE: NONE DATE: 02/28/2023

JOB NO. \ FILE NAME:	DESIGNED BY: G.G.C.	PLAN NO.
FILE.DWG	DRAWN BY: G.G.C.	5 OF 6
	CHECKED BY: J.A.M.	

FOR REFERENCE:
UNLESS OTHERWISE SHOWN, WATER METERS SHALL BE INSTALLED WITHIN THE BUILDING STRUCTURE.

BEFORE: 1 PARCEL

BUILDING PERMITS ISSUED MANY YEARS AGO ALLOWED THIS SERVICE CONFIGURATION.

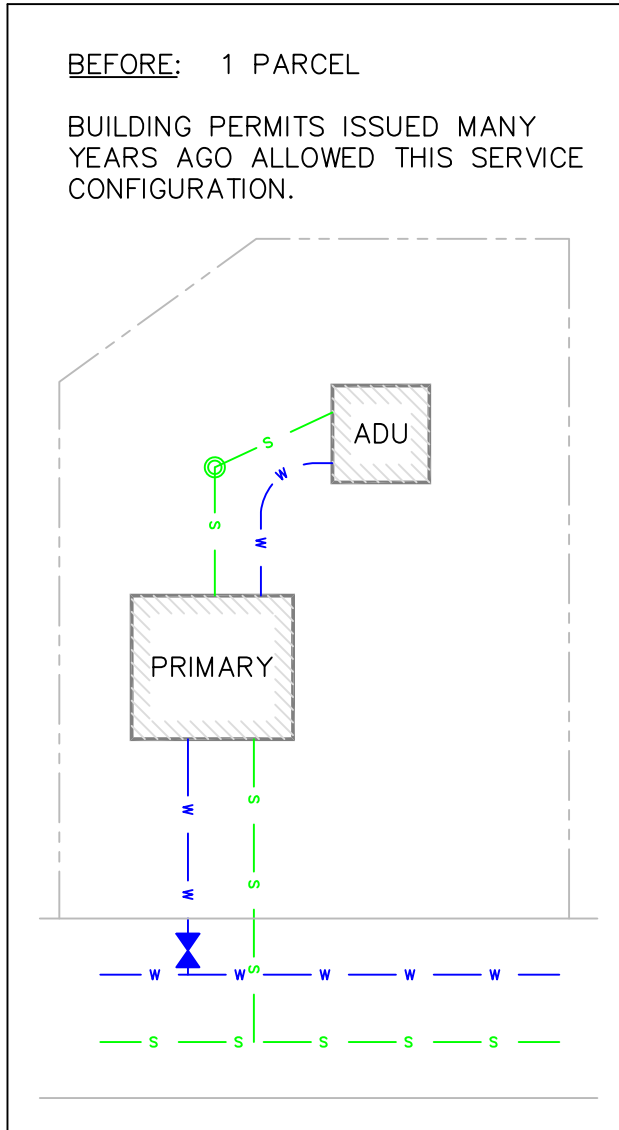

AFTER: 2 PARCELS

SUBDIVIDED PARCEL W/ACCESSORY STRUCTURE ON NEW LOT & RETAINS SEWER CONNECTION.

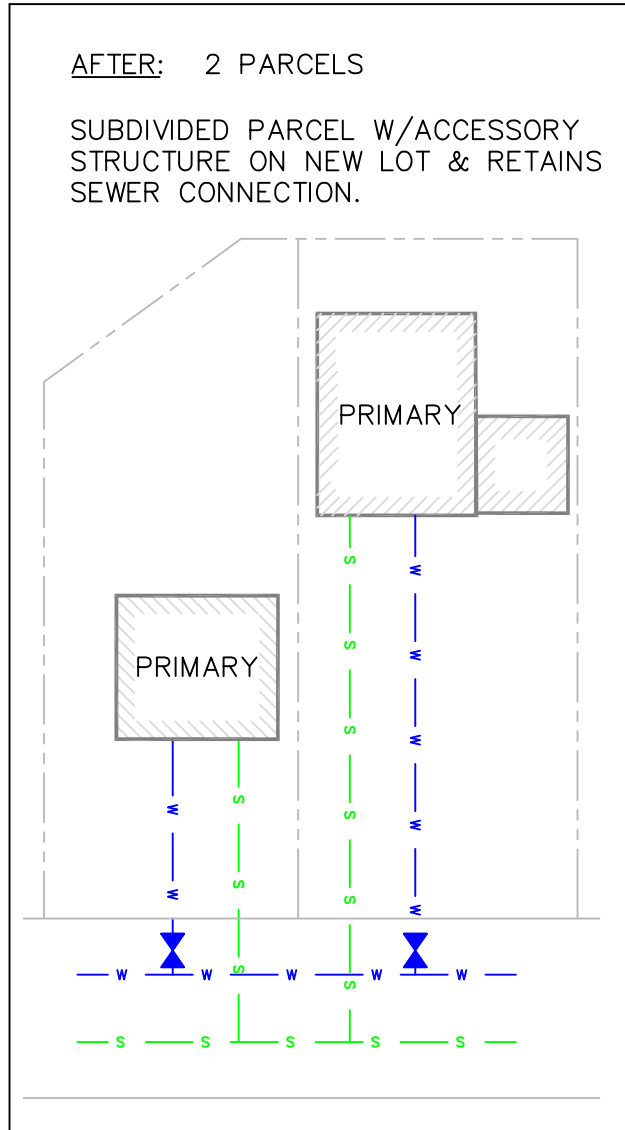

SUBDIVIDED PARCEL, WITH ORIGINAL ADU ON NEW LOT AND NEW LOT RETAINS SEWER CONNECTION

CONFIGURATION STANDARDS APPROVED AS POLICY BY CONCORD PUBLIC WORKS COMMISSION ON MARCH 8, 2023.

LEGEND

- SEWER LINE — s —
- WATER LINE — w —
- WATER METER PIT M
- WATER VALVE ⋈
- SEWER MANHOLE
- SEWER CLEANOUT ○

TOWN OF CONCORD—PUBLIC WORKS
WATER & SEWER DIVISION
STANDARDS

*ACCESSORY DWELLING UNIT AND
ACCESSORY STRUCTURE TYP. LAYOUTS*

SCALE: NONE

DATE: 02/28/2023

JOB NO. \ FILE NAME:
FILE.DWG

DESIGNED BY: G.G.C.
DRAWN BY: G.G.C.
CHECKED BY: J.A.M.

PLAN NO.
6 OF 6